

F-720-S

PANADERO



MESURES

DIMENSIONS H x L x P	613x700x471 mm
POIDS BRUT/NET	125/110 kg
PORTE ENTREE BOIS	550x311 mm
SORTIE DE FUMÉES	Ø 150/153 mm Verticale

CARACTERISTIQUES

GRILLE ET PORTE EN FONTE	
PUISSANCE	6,7 kW
RENDEMENT	80,7 %
EMISSION DE CO	0,12 %
PEINTURE ANTICALORIFIQUE RÉSISTANCE	800°C
VERRE VITROCÉRAMIQUE RÉSISTANCE	750°C

EAN 8426964190502
REF. PANADERO 19050

PLUS PRODUCT

ECODESIGN



COMPATIBLE BBC
COMFORME RT 2012
PRISE D'AIR EXTÉRIEUR



VOLUME DE
CHAUFFE



FOYER REVÊTU EN
VERMICULITE



SYSTÈME VITRE
PROPRE



TRIPLE
COMBUSTION



BÛCHES DE 50 CM



PORTE EN VERRE
SERIGRAPHIÉ

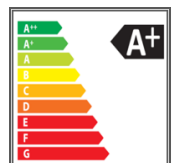
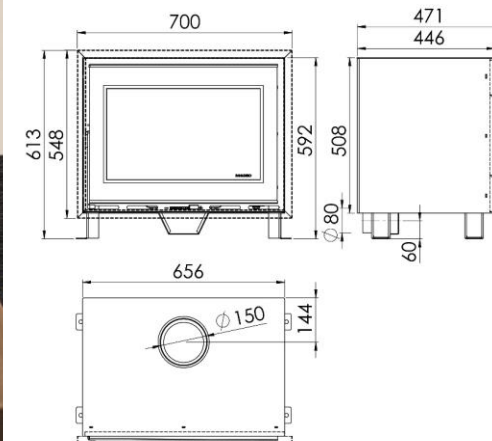

F-720-S FR

